

# FENDT

Fendt 1000 Vario





500 hp for your best work, every day.  
Fendt 1000 Vario.

Big. Strong. Unique. A true masterpiece coupled with leading Fendt technology. Experience true strength, full traction, expert control and intelligent networking with the Fendt 1000 Vario.



## The Number One for heavy draft work.

Fendt 1000 Vario harnesses its power. Its large tyres, intelligent ballasting and tyre pressure assistant as well as unique, variable four-wheel drive deliver the right amount of grip in any situation – along with outstanding manoeuvrability. And it has more than just pulling power.

Engine		1038 Vario	1042 Vario	1046 Vario	1050 Vario
Rated power ECE R 120	kW/hp	291/396	320/435	350/476	380/517

**Most powerful standard tractor with maximum modularity**

The Fendt 1000 Vario occupies a new segment with its power output. Its design as a high-performance standard tractor brings together every advantage for operations in the field and on the road.

- Power class 396–517 hp
- 14t unladen weight at a permissible overall weight of up to 23t\*
- 60" (1.5 m) trackable\*\*
- Full roadworthiness at 60 km/h\*
- Optional rear PTO on 1000, 1000E and 1300
- Optional rear linkage
- All hitch systems in modular design
- Optional reverse drive control
- New generation of LED work lights

\* Figure depends on country-specific legal requirements.  
\*\* Depends on country variants.



**Maximum performance 365 days a year**  
All components from engine to gearbox, from radiator to hydraulics, have been designed specifically for permanent power in demanding applications, and tailored to high power transfer with very low consumption. Of all its strengths, the Fendt 1000 Vario shines due to its excellent manoeuvrability and low tare weight with high payload. The latest software solutions and variety of interfaces pave the way for connected services, which boost operational efficiency with high-speed data analyses and maintenance options while still working in the field.

So that daily work becomes a masterpiece.

## FENDT ID LOW ENGINE SPEED CONCEPT

# High power – low fuel consumption. Fendt iD.

### Fendt iD low engine speed concept

The Fendt 1000 Vario always runs within the maximum torque range for the lowest specific fuel consumption, which means that high power is already delivered at low engine speeds. “High torque, low engine speed” is the system according to which all vehicle components such as engine, gearbox, fan, hydraulics and all auxiliary units are tailored to suit the ideal engine speed.

### High torque – low fuel consumption

The Fendt iD low engine speed concept results in permanently low fuel consumption and an extended service life. The speed band of the Fendt 1000 Vario ranges from 650 rpm to 1,700 rpm. In the main working range, the speeds range from 1,100 to 1,500 rpm, which is gentle on the components and lowers consumption. The engine of the Fendt 1050 Vario already delivers an impressive 2,400 Nm of torque at just 1,100 rpm.

### The way Fendt iD works

The entire drive technology of the Fendt 1000 Vario is exceptionally efficient. The high-capacity engines with VTG turbocharger unfold their enormous power potential efficiently at low engine speeds. Transmission and variable four-wheel drive ensure ideal power distribution within the optimal consumption range. The Concentric Air System (CAS) cooling concept with forced-draft high-performance fan cools all heat exchangers according to needs and further increases overall efficiency. All consumers, such as the air-conditioning, air compressor or alternator, are coordinated for low wear through low engine speeds.



THE ENGINE ON THE FENDT 1000 VARIO

# A master of heavy draft work.

**396 to 517 hp:**

It is powered by the highly efficient MAN six-cylinder engine. With a 12.4-litre cubic capacity, it reaches a high amount of torque even at low engine speeds: On the Fendt 1050 Vario, the maximum torque of 2,400 Nm is there at just 1,100 rpm – perfect for heavy draft work. This fast high-horsepower tractor reaches its top speed of 60 km/h at just 1,450 rpm, and 40 km/h at a fuel-saving 950 rpm.

**Economical, low-emission, environmentally friendly**

The smart solution for compliance with the new Emissions Stage V is decisive for the economy of the drive train. So, we equipped the engine with an exhaust after-treatment that enables the lowest fuel and AdBlue consumption. Exhaust after-treatment is a combination of SCR technology, the diesel particulate filter and the diesel oxidation catalyst.

**Turbo efficiency**

The engine, tried and tested many times in the truck segment, has been tailored to heavy loads based on the load spectrum in heavy field work. The charging is done through the VTG turbocharger and results in high torques even at low engine speeds. Low engine noise level and exhaust brake via the VTG, which is gentle on the brakes and minimises wear.

**Reversible fan**

Quick, easy radiator cleaning without downtime – thanks to the reversible fan. This can reverse the air stream automatically – now as a headland management sequence – so the cooler elements are effectively blown clean.

The cooling water level and the degree of air filter contamination are shown in the Varioterminal.



The 12.4 l MAN engine with common rail attains high injection pressure of 1,800 bar and is therefore very efficient.

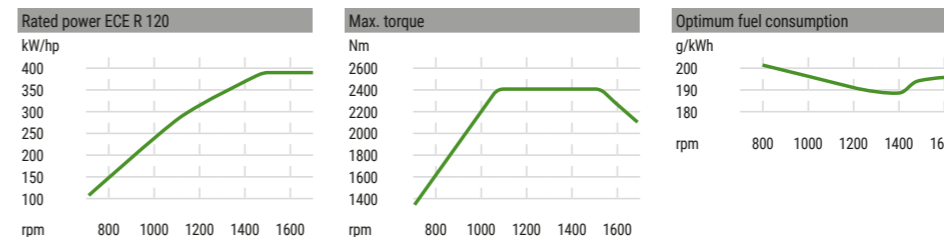

**Engine characteristics – Fendt 1050 Vario**

Through the well-rounded torque curve, more power is already available in the lower speed range. Furthermore, the constant power range provides a broader engine speed band over which the maximum power can be called up. In this range, the rated speed is equivalent to the maximum power.

FENDT VARIODRIVE

# Drives your success – at full power.



### From Vario to VarioDrive

The Fendt Vario stands for stepless, dynamic driving with plenty of engine power at any speed from 0.02 km/h to 60 km/h. The new Fendt 1000 drive has been specifically developed with the aim of transmitting high engine horsepower in any situation, regardless of ground conditions, and therefore keeping the engine speeds very low. The solution: Fendt VarioDrive – the drive train that drives both axles independently for the first time.

### Variable 4WD gives you 500 hp

Conventional four-wheel drives usually have a fixed torque ratio between the front and rear axle. Fendt VarioDrive enables a variable four-wheel drive. The torque is essentially distributed to both axles via two gearbox outputs. Thanks to the intelligently-controlled 4WD clutch, torque displacement takes place when required between the axles. This is called Fendt Torque Distribution.

### Masterpiece with grip(s)

During field work, torque is transferred when needed to the axle with grip tyres. The result is tremendous pulling power. As the speed increases, a clutch completely decouples the front axle drive at approx. 25 km/h – this eliminates drag losses in the drive train and increases efficiency.

### Tightest turning circle, with 'pull-in-turn'

As there is no fixed forward ratio due to the variable 4WD, the front wheel drive is able to actively pull the tractor into the turn – the 'pull-in turn' effect. This effect alone reduces the turning circle on the field by up to 10%. VarioDrive minimises the otherwise usual tyre wear on the front tyres caused by cornering on firm substrates.

New, larger high-capacity 370 cm<sup>3</sup> hydrostats ensure very high transmission efficiency. The separate oil supply protects the gearbox against oil mixing and contamination.

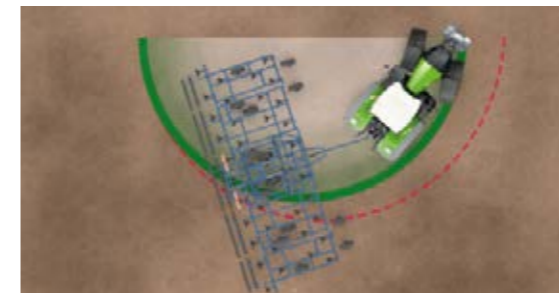
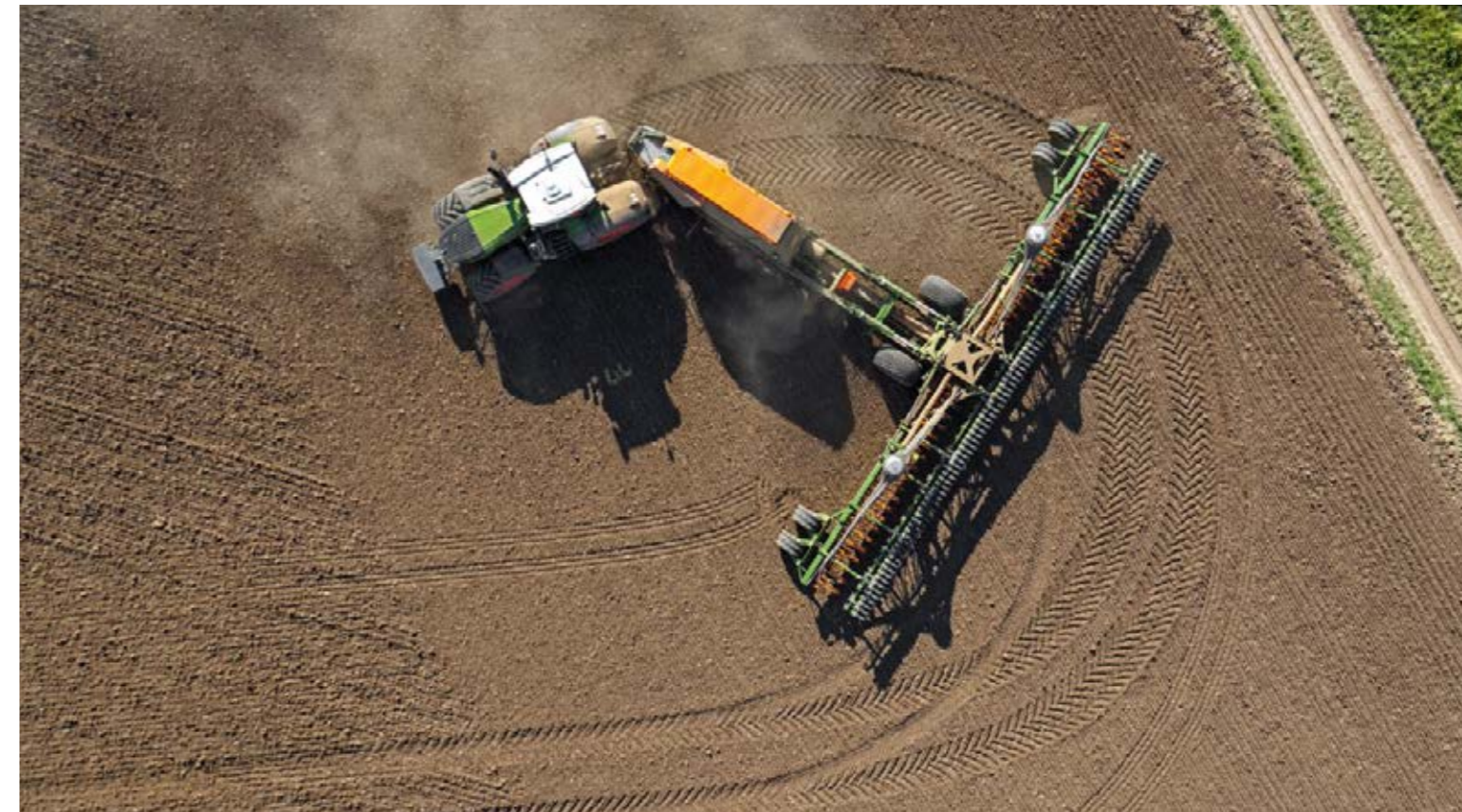

Small turning radius thanks to "pull-in turn" effect, e.g. 6.97 m for the Fendt 1038 Vario with standard tyres.

## THE HYDRAULICS FOR THE FENDT 1000 VARIO

# Everything flows.

### Versatile hydraulics

The modular design of the hydraulics opens up a whole range of options. The valves come in a choice of UDK, DUDK and FFC couplings. You can use the right attachment, every time; the system includes ½" and ¾" valves with a maximum flow rate of 140 l/min and 5/8" valves with a maximum flow rate of 170 l/min. The DUDK and FFC couplings can be coupled under pressure from both sides.

### Coupling system with many advantages

On the one hand, the flexible system enables fast machine changes independent of coupling size. On the other, the fleet can be gradually converted to larger valves. It also comes with all the advantages of flat-face FFC couplings: a large diameter of 5/8" for more flow, leak-free coupling, greater efficiency thanks to fewer pressure drops, easy cleaning, and a longer lifetime as less dirt gets into the coupling. All valves have a breakaway function without pressure loss.

### Twice as strong

Alongside load-sensing pumps with 165 l/min or 220 l/min pump capacity, the Fendt 1000 Vario has high-performance hydraulics with 430 l/min – for the toughest of requirements. On 2 separate circuits, one pump delivers 220 litres and a second 210 litres. So, you have 2 control pumps supplying multiple oil extractors – controllable with up to 6 da valves at the rear and 1 da valve at the front. The separate hydraulics and transmission oil supplies means the 1000 Vario will be compatible for use with bio-oil in the hydraulic circuit.

### Oil flow according to need

Both control pumps supply the respective separator via its own oil circuit with the ideal quantity of oil and the right oil pressure. For example, the fan of a pneumatic sowing machine requires a high flow rate, but low pressure, while the remaining consumers, such as steering, power lift, chassis or markers, also require high oil pressure at a low flow rate on the second circuit.

Two valves can be prioritised for the dual-circuit high-capacity hydraulics.



You can opt to have the replaceable couplings screwed into the block and quickly replaced depending on the attachment you want to use.

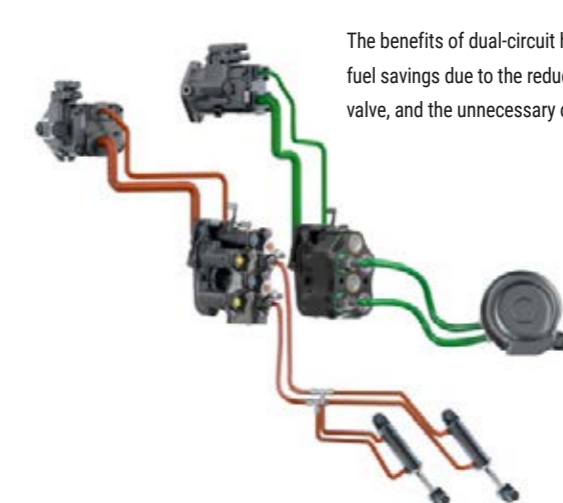

The benefits of dual-circuit high-capacity hydraulics are clear – effective fuel savings due to the reduced throttle losses on the pressure limiting valve, and the unnecessary oil heating associated with it.



FENDT LIFE CAB

# Comfort leads to success.



Practical for front mounted implements: The camera integrated in the bonnet captures the view to the lower links and transmits the image to the Varioterminal.

**Field work with comfort factor**

The Fendt 1000 Vario already makes climbing in easy: wide steps with side lighting lead upwards. All the hand grips are intuitively correctly placed. The soft touch surface of the interior panelling creates a pleasant atmosphere and is resistant against dirt and dampens noises. The Comfort Seats turn heads with their black leather cover for both the operator and passenger seats. The adaptive backrest of the Dualmotion comfort driver seat swings with you when you look over your shoulder.

**New visibility range**

The Fendt 1000 Vario tows the largest and widest implements, which the operator has in full view through the large windows. The new design of the cab offers up to 10% more visible area than the previous Fendt high-horsepower tractor cabs. The manual roller shades integrated in the roof on the front, rear and right side window, offer sun protection. Free visibility, even when it rains: In addition to the 300° wiper for the front, a 220° wiper including spray nozzle is now available for the right side.

**Infotainment package with sound experience**

Four high-end speakers and a subwoofer deliver superior sound quality in the cab. Enjoy playback from your smartphone via USB, AUX-IN and Bluetooth. FM/AM/DAB+/HD and two antennas with permanent channel search also ensure excellent radio reception. Make phone calls in your Fendt 1000 Vario with a fantastic quality hands-free kit: A total of 8 microphones built into the roof liner guarantees the perfect acoustics, picking up your voice every time. Controls are on the Varioterminal and the side membrane keypad.

**Electrically adjustable comfort mirrors**

The rear and wide angle mirrors can be easily adjusted electrically on the terminal. The mirror brackets also go in and out easily. Blind spots are a thing of the past. Even when using large attachments in tight spaces, the driver has the best overview at all times.

You can opt for electrically adjustable and extendible mirrors, so you can adapt them to different vehicle widths. You can do all this from the comfort of your cab on the Varioterminal.



The high-capacity automatic climate control with twin blowers and larger air nozzles keep the Life Cab pleasantly cool, even at temperatures up to 45°C.

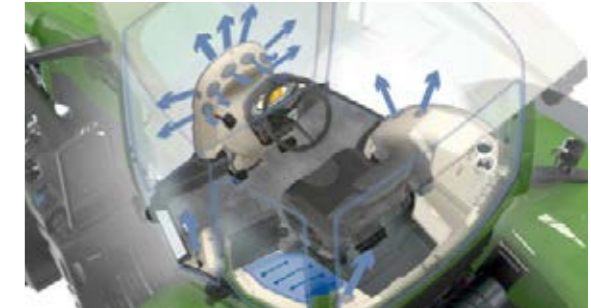

The front and rear windows are heated, which is a big advantage when operating with the reversing driver station.



Precise sun protection with one hand movement, also on the right-hand side window.



The new Infotainment bundle with a 4.1 sound system delivers an outstanding quality of sound thanks to 4 high-end speakers and a subwoofer.

SMART SOLUTIONS IN THE FENDT 1000 VARIO

# New paths for a higher yield: Precision farming.



Whenever you buy a product or service with the Fuse logo, you can enjoy guaranteed open connectivity and compatibility within our core brand ranges as well as with other manufacturers' products.

To find out more, go to [www.FuseSmartFarming.com](http://www.FuseSmartFarming.com)

### Fendt Connect telemetry system

Our basic telemetry package is the best way to analyse and manage your fleet. Fendt Connect can read, store and analyse machine data as part of the package. This makes it easier to plan usage times and machine capacity, which ultimately helps you increase the cost-effectiveness of your vehicles. View machine data on your PC or smart device, including:

- Machine position and route (map view)
- Fuel consumption
- Speed
- Operating time
- Machine capacity
- Error messages
- Upcoming service intervals

And more.

### Realtime display with Smart Connect

The optional Smart Connect app visualises machine parameters in real time without storing any data. As a trusted brand of agricultural solutions, data security is extremely important for Fendt. Using digital Fendt devices is subject to strict European IT security standards.

### Always on track – Fendt VarioGuide with Contour Assistant

With VarioGuide – the central track guidance system for Fendt machines – you always work with the utmost precision. Choose from two receiver options (NovAtel® or Trimble®) and a variety of correction data signals. The Fendt VarioGuide with Contour Assistant helps you work even more efficiently and easily with the new VarioGuide wayline types, Contour Segments and Single Track. With Contour Segments, you can use different waylines at the same time. The tractor automatically switches to the right wayline based on its current direction and position. The guidance system is a big help on the headland.

### Needs-based management with SectionControl and VariableRateControl

Easily control both the fully automated SectionControl and the section-specific application of products with VariableRateControl on the Varioterminal.

### Up to date. Even in the future. Fendt software updates

With our software updates, your Fendt 1000 Vario will always be up-to-the-minute, even in years to come. Just have your dealership install the latest updates free of charge up to twice a year during a regular service (labour is charged).

The Variotronic® auto headland management stores all your turning sequences and puts them into motion at exactly the right time.



Control ISOBUS-capable implements either by joystick or on the Varioterminal.



Thanks to the well-organised armrest – consisting of a 4-in-1 Varioterminal, multi-function joystick, crossgate lever, EHR power lift, valve control and membrane keypad – you've got everything under control.



The data from the field is saved in the field database by VarioDoc. VarioDoc Pro also records GPS position data and data transfer in near realtime.

# Makes your work easier.

With Fendt VarioGuide, you have a choice of two receivers, NovAtel® or Trimble®:

**NovAtel® receiver**



**NovAtel® Standard**  
Correction signal: SBAS (EGNOS & WAAS)  
± 15-30 cm track to track accuracy; ± 150 cm repeatable accuracy

**NovAtel® – extendible correction signals**  
Correction signal: TerraStar-L  
± 15 cm track to track accuracy; ± 50 cm repeatable accuracy  
Correction signal: TerraStar-C  
± 4 cm track to track accuracy; ± 4 cm repeatable accuracy

**NovAtel® RTK**  
Correction signal: RTK  
± 2 cm track to track accuracy; ± 2 cm repeatable accuracy  
Mobile network / radio

**Trimble® receiver**



**Trimble® Standard**  
Correction signal: SBAS (Egnos & Waas)  
± 15-30 cm track to track accuracy; ± 150 cm repeatable accuracy

**Trimble® – extendible correction signals**  
Correction signal: RangePoint® RTX  
± 15 cm track to track accuracy; ± 50 cm repeatable accuracy  
Correction signal: CenterPoint® RTX and CenterPoint® RTX Fast  
± 4 cm track to track accuracy; ± 4 cm repeatable accuracy

**Trimble® RTK**  
Correction signal: RTK  
± 2 cm track to track accuracy; ± 2 cm repeatable accuracy  
Mobile network / radio

Because the receivers are installed under the roof hatch, they are fully protected against theft, weather and damage.

- NovAtel®:**
- High-performance standard receiver
  - Optional use of RTK ASSITM: Bridging during RTK dropouts of up to 20 minutes

- Trimble®:**
- Extremely efficient receiver with even more options
  - Up to 20 minutes' bridging if the RTK connection drops (Trimble®-xFillTM technology)
  - Optional use of xFillTM Premium (unlimited bridging)

The Power joystick has two buttons for the Variotronic™ headland management system, 2 cruise control settings and an engine speed memory. The Varioterminal 7" gives an excellent overview.



The Profi joystick has four buttons for the Variotronic™ headland management system, two cruise controls, two engine speed memories and buttons to control two hydraulic valves. The Varioterminal 10.4" has two camera inputs.



**VarioGuide Contour Assistant**

The VarioGuide Contour Assistant software option adds Contour Segments and Single Track to the familiar VarioGuide wayline types. This makes your field work even easier and more efficient.

**Contour Segments wayline**

Until now, drivers have had to record different waylines so they can work on the different sections of field. They also had to manually switch between the waylines as they worked. You can use the Contour Segments wayline to record each segment and wayline in a one-off circumnavigation of the field, or apply them directly from the existing field boundary. All relevant waylines are grouped into one unit. Contour Assistant automatically detects the right track.

**Single Track wayline**

Use Single Track to record an almost endless track with an open contour. You no longer need to automatically generate parallel tracks. This feature is ideal for plant protection, as you can record a single track and apply it to the whole field.

**Variotronic™ headland management**

With the Variotronic™ headland management system, you can apply any of your turning sequences at the touch of a button. You can store up to 25 implements. In combination with VarioGuide, Variotronic™ automatically detects the position and automatically initiates all the recorded steps at the headland.

**Documentation with Fendt VarioDoc**

Field data is stored in the field database with the VarioDoc documentation system. VarioDoc Pro also records GPS position data and transfers the data in near realtime.

2 installation levels available	VarioDoc	VarioDoc Pro
<b>USB data transfer</b>	✓	✓
<b>Bluetooth data transfer</b>	✓	✓
<b>Mobile network data transfer</b> New and completed jobs		✓
<b>Semi-automatic documentation</b> Under trigger conditions (rear power lift, PTO...)	✓	✓
<b>GPS location data (every 5m)</b> Example: Speed, engine speed, consumption...		✓

FENDT VARIODRIVE – THE DRIVE

# The success factor for grip.



The Grip Assistant recommends the right tyre pressure and ballasting for a defined speed when in Speed Select mode. In Ballast Select mode, the assistant recommends the ideal working speed as well as the optimal tyre pressure for a defined ballast.

**VarioDrive drive train – a master in power distribution**  
The novel design of the drive train allows the ideal torque distribution to front and rear wheels for optimal traction and tractive power. The drive train is based on a hydraulic pump and two hydro motors. The first hydro motor supplies the rear axle with uninterrupted torque via hydrostatic-mechanical power splitting from 0 km/h to 60 km/h. The second hydraulic motor serves the front axle. Through feedback to the rear axle, from the ground or through the intelligently controlled four-wheel clutch, the front axle drive also becomes part of the hydrostatic-mechanical power splitting.

**Power distribution through Fendt Torque Distribution**  
The flexible torque distribution of the variable four-wheel drive is achieved through a T-piece, which is located between the hydraulic pump and the hydraulic motors for the front and rear axles. It acts as a hydrostatic differential between the axles and permits the oil flow between the pump and hydraulic motor to be adjusted freely. As a result, there is no tension. If needed, torque can be automatically shifted from one axle to the other via the intelligently controlled four-wheel clutch. Frictional loss and wear are reduced effectively.

**Fendt VarioGrip for the perfect tyre pressure**  
Due to their large diameter of up to 2.35 metres, the rear tyres on the Fendt 1000 Vario have a very large contact area, which has a positive impact on traction and therefore tractive power. This always includes having the right tyre pressure. With the integrated tyre pressure regulation system Fendt VarioGrip, the tyre pressure can be adjusted with a click in the Varioterminal. The tyres are inflated or deflated while you're on the move. Compared to working with unadjusted tyre pressure, you can achieve up to 10% more pulling power and cover up to 8% more area with up to 8% lower fuel consumption.\* VarioGrip is available for flange and bar axles, and forms the basis for tyre pressure adjustment at the touch of a button, even with dual tyres.

\* Test results from South Westphalia University of Applied Sciences, Faculty of Agriculture, Soest.

**Perfectly ballasted with the Fendt Grip Assistant**  
Besides the tyre pressure, the ballasting and working speed are also decisive for power transfer to the ground. The new solution is called: Fendt Grip Assistant. Fully integrated in the Varioterminal, this Assistant quickly determines the right tyre pressure, ideal ballast weight and driving speed. Depending on the implement or ballast of the tractor, the Grip Assistant recommends either front and wheel weights, or the optimal working speed.

Diagram showing the Fendt VarioDrive design.

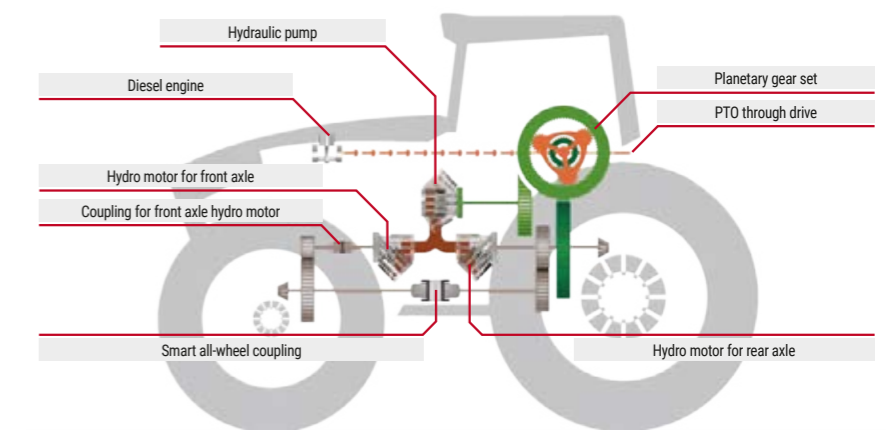

**Front axle suspension**  
The self-levelling independent wheel suspension on the Fendt 1000 Vario guarantees optimal ground contact of the front wheels under all conditions, and reliably prevents power-hopping for the ultimate in pulling power. Ride comfort and safety are also maintained when transporting at up to 60 km/h. The long suspension travel maintains ride comfort independent of the load. The driver can manually override the suspension travel, to use the easy ballast pickup without front power lift, for example. More benefits: The single wheel suspension is maintenance-free.



Front axle with self-levelling independent wheel suspension and single wheel brake.



The perfect integral tyre pressure regulation system VarioGrip controls tyre pressures from 0.6 to 2.5 bar within minutes. The optimal tyre pressure saves fuel, protects the soil and increases traction.

# Assistants for reliability.

### Engine-gearbox assistants

Engine and transmission are automatically aligned with the Tractor Management System (TMS). The TMS controls the engine speed and transmission setting automatically, independent of the speed, so that the tractor is always moving at maximum efficiency, thus saving fuel. The engine load reduction is controlled by the automatic maximum output control 2.0, depending on implement operation.

### Driver assistance

Driving safety matters, on the road and in the field. The unique Fendt Stability Control (FSC) provides additional stability and steering precision when driving above 20 km/h on the road. When coming out of a turn, the Fendt Reaction steering system automatically switches to straight-ahead driving. The superimposed steering system VarioActive makes light work of steering: a single turn of the steering wheel is enough for a full steering angle.

### Braking assistants

A highlight you wouldn't want to miss: In auto mode, the new Handbrake Assistant automatically activates the handbrake when you climb out of the cab or turn off the engine. And vice versa, the assistant automatically deactivates the handbrake when starting off. If you stop and take your foot off the brake pedal, the tractor stays standing safely, even on slopes. The Deceleration Assistant, which automatically actuates the brake lights when decelerating more than  $1\text{m/s}^2$ , even before actively braking, provides additional safety when braking. This provides an early warning for traffic following the tractor.



With VarioActive, you already go through the full steering angle with just one turn of the steering wheel.



Hand brake assistant in automatic position: The hand brake is automatically activated.



Thanks to the TMS tractor management system and the automatic maximum load control 2.0, the tractor adapts the engine speed optimally to the road speed.

# Cab.

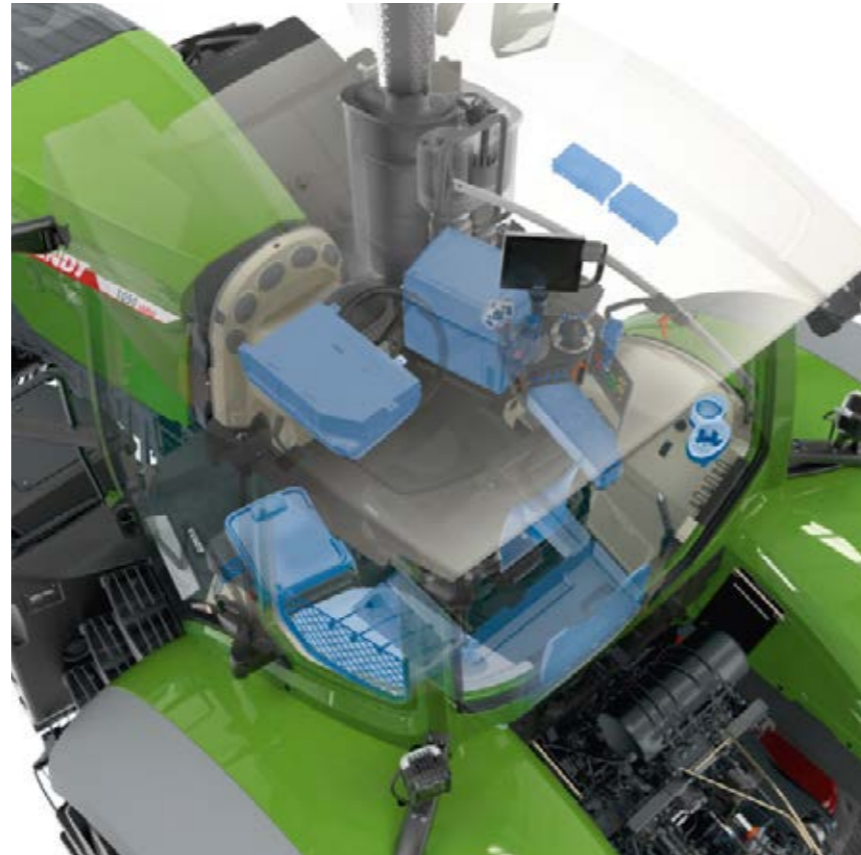

The Life Cab is a masterpiece in terms of storage options: Up to 18 storage points, from a bottle holder for several large bottles, to a large storage compartment in the roof liner, up to the cooling compartment and several document compartments behind the driver seat and on the sides.



The 4-fold bearing, pneumatic comfort cab suspension with integral level control reduces vibrations to a minimum.



The mechanical cab suspension rests on two conical bearings at the front and on two mechanical spring elements at the rear.



The super comfort seat Evolution dynamic has air-suspension and active climate control as well as a backrest extension.



The new Fendt Evolution Dual Motion comfort seat with seat heating, climate control and Dual Motion swing-along backrest, is extremely comfortable and ergonomic.



The new black leather version of the Fendt Evolution Dual Motion comfort seat active with active suspension is especially classy and dirt-resistant – and always comes with a comfort instructor seat in leather.



The integral cable lead-through permits clean cable routing with closed rear window, protects against dirt, water and noise. No cable spaghetti: All cables are fixed in the cable guide in the C-pillar.

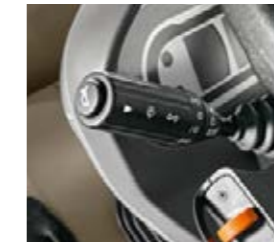

Like every Fendt, the Fendt 1000 Vario also makes the working day easier through small, practical details like the automatic blinker reset: the tractor blinks automatically until the turn has been completed.



With the help of the interior rear view mirror, you always have your implement in view.



The 220° side window wiper also guarantees an optimal view to the right side, even in adverse conditions.

FENDT 1000 VARIO

# Cab.



For enhanced operating comfort, the cockpit swings parallel with the steering wheel. Easy steering wheel adjustment via a separate foot pedal, leaving the hands free for other movements.



When operating in reverse drive mode, all control elements can be operated just as comfortably as in front drive mode. The entire driver station is simply turned around 180° – and everything else in the cab can remain where it is. Despite the reversing driver station, passengers do not have to do without the comfort seat.

FENDT 1000 VARIO

# Lighting.

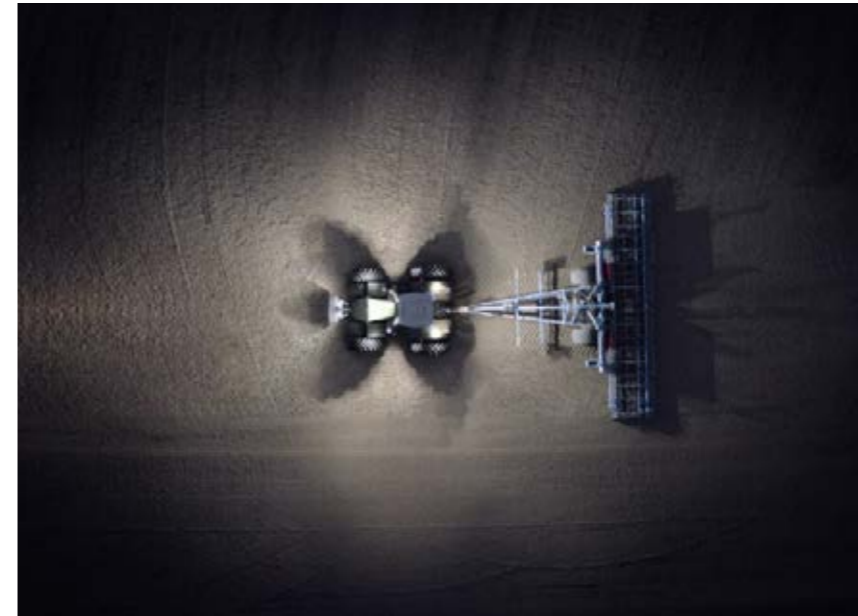

Fendt 1000 Vario ensures top performance at night with the new generation of LED work lights with 61,100 lumen. Whether equipped with LED or Halogen lamps, the complete working area is uniformly lit. The interior of the cab also makes night work pleasant: All operating elements are backlit and dim automatically when it gets dark. With the coming home feature, the cab and driving lights continue to shine after the tractor has been turned off.



LED daytime running lamps and work lights are integrated in the front of the bonnet; camera included.



The variants without daylight running lights and work light retain an attractive appearance through designer trim.



The headland range can be set manually with the rotary control in the roof liner.

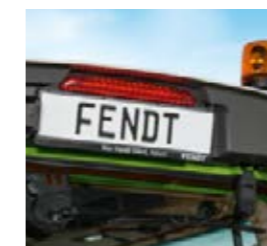

The Fendt 1000 Vario has a third brake light for greater safety on the road.



The entrance step lighting integrated on the side of the tank guarantees safe entering and exiting the cab.

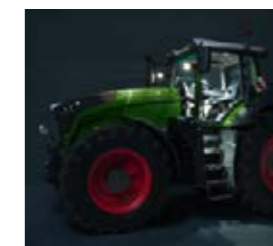

With the coming home function, the main lights and the lights on the steps continue to shine after the engine has been turned off so that the way home, as well as the steps, are illuminated.



The ambient lighting creates a pleasant atmosphere when working at night. All functional elements have backlighting.

# Power lift and hydraulics.



The Fendt 1000 Vario can be customised by upgrading or downgrading. The fully equipped rear area has all the connections and functions, such as Power Beyond, ISOBUS socket, rear return, PTO and rear power lift.



Simpler rear equipment, e.g. no rear power lift and PTO still offer the complete range of modular hitch systems, which can be exchanged as needed.



The self-closing valve flaps protect against contamination and enable one-handed coupling.



The front lift is perfectly integrated in the vehicle.



The Fendt 1000 Vario provides connections for up to seven control units, six at the rear and one in the front.



With the DCUP couplings you can couple all hydraulic valves under pressure on both sides. The pressure relief lever permits easy coupling.



Using the comfort ballast pickup, front weights can be picked up quickly and easily, even without front linkage.



With the external valve controls, you can actuate the rear linkage, one valve and the PTO directly on the rear mudguard.



For non-European standards, the rear can also be equipped with rub blocks and a quick hitch frame. Optionally, the Fendt 1000 Vario can be fitted with a 60" track.

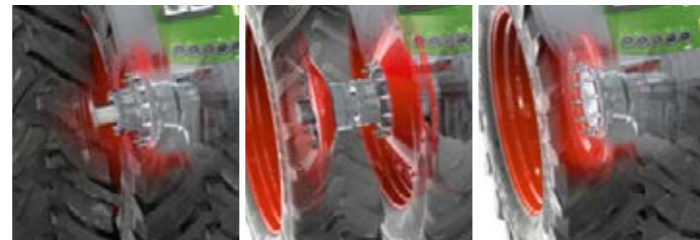

The Fendt 1000 Vario offers a flanged axle or an axle stub variant to meet different requirements.

# Ballast and hitch systems.

Piton Fix is available in standard and heavy-duty versions.

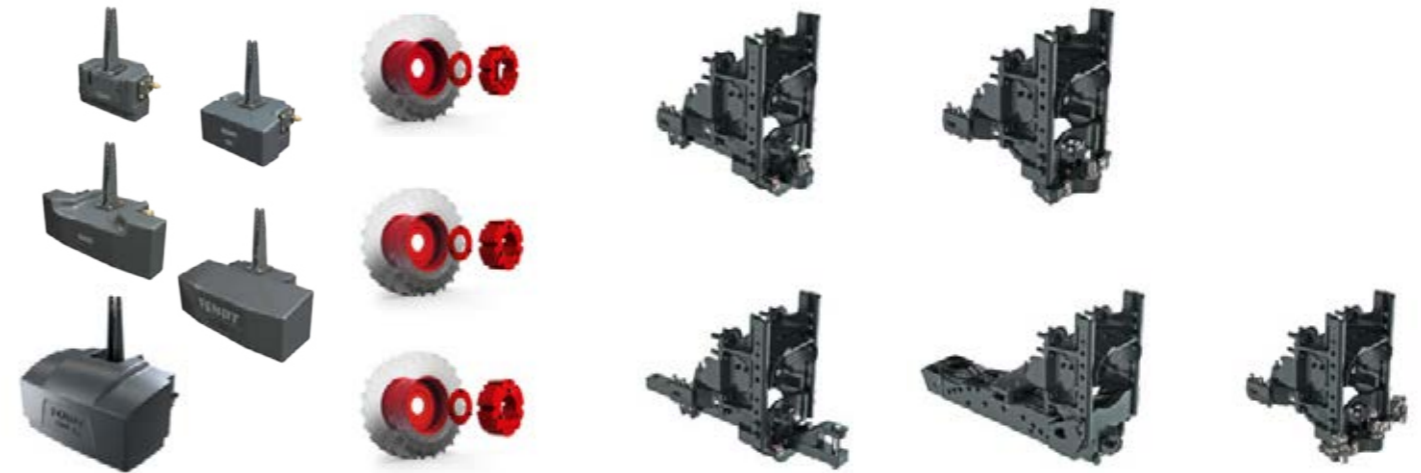

The Fendt 1000 Vario has highly-flexible ballast options. A range of front weights from 870 kg to max. 3300 kg are available, as well as wheel weights from 2 x 650 kg each up to 2 x 1250 kg.

The pull-out Cat. 4 drawbar with 50 pins can be adjusted in length.

Hitch permits fast and easy hitching.

The ball-type coupling including forced steering left and right allows the trailer to be steered actively.







## FENDT SERVICES

# The best product with the best care and service.

With Fendt, you get a cutting edge product that will overcome the toughest of challenges. That's why you can expect that little bit extra when it comes to services from highly-efficient, certified Fendt dealers:

- Fast lines of communication between you and our trained service team.
- 24/7 availability of replacement parts throughout the season
- 12-month warranty on Fendt original parts and their fitting

**100% quality. 100% service: Fendt Services**  
We offer outstanding services to offer you the best possible reliability of use and efficiency from your Fendt Machine:

- Fendt Demo service
- Fendt Expert operator training
- AGCO Finance – finance and lease deals
- Fendt Care – servicing and guarantee extensions
- Fendt Certified - Pre-owned machine programme



+44 330 123 9909

Your Fendt dealers are always there when you need them, and have just one aim – to make sure your Fendt machines are ready for action at any time. If something does go wrong during harvest time, simply call your certified service centre 24/7 on the emergency hotline.

FENDT SERVICES

# Rest assured that your machine will be ready for action tomorrow.

**Fendt Demo service**

Is this a new purchase? You'll love our Fendt solutions and overall efficiency. Let the Fendt Demo service make the decision easier.

**Fendt Expert operator training**

We help you get the most out of your vehicle. With the help of our exclusive Fendt Expert operator training programme, you can optimise the efficiency of your Fendt even further, and get to know all the functions to make your daily routine that much easier. Our team of professional trainers will advise you on how to use your Fendt machine to its full potential.

**Individual finance and lease models**

Investing in technology means a considerable capital outlay. A credit finance agreement from AGCO Finance offers attractive conditions and flexible terms. From the initial down payment to monthly instalments to the payment term – you set the general terms on which to finance your Fendt. If you need additional resources in a hurry or want to use tractors over a long-term period without purchasing them, your Fendt dealer can offer the ideal solution with tailored lease packages.

**Fendt Certified - Pre-owned machine programme**

Leaders drive Fendt – including with pre-loved agricultural machinery. Used agricultural machinery to tried and tested high-quality standards and certified Fendt quality – the ideal solution for cost-conscious farmers or as an addition to a growing fleet.

The benefits:

- Certification according to strict quality standards
- Extensive incoming check (technology, wear, appearance)
- Fully serviced wear parts
- If required, replace, clean and paint components
- One-year warranty (option to extend)

**Fendt Care – servicing and guarantee extensions**

To keep your machine ready for action at any time, we offer a tailored maintenance and repair service beyond the statutory warranty. This only covers the repair risk of a new machine for the first 12 months after delivery. That's where Fendt Care comes in. With flexible durations and flexible rates with and without excess, the machine can be guaranteed even after the first year. Your Fendt dealer will only install Fendt original parts. These have a proven standard of quality and are safety-tested. This ensures the best value retention for your Fendt machine.

Using the smartphone app "AGCO Parts Books to go", you can find Fendt spare parts quickly and easily and order them directly. The app is available for download in the app store and in the Google Play Store. Your personal access data is available from your Fendt dealer.

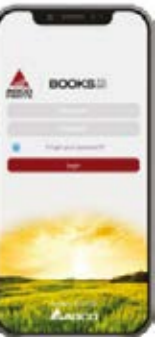

## Full control over costs and planning reliability

Fendt Care	Bronze	Silver			Gold <sup>1</sup>	Platinum <sup>1</sup>
Service	Regular maintenance, fixed maintenance costs	Cover against the risk of repair (excludes wear)			All costs covered (except wear and tear)	Costs and availability covered (except wear and tear)
Benefits	Reliability of use	Coverage against major damage	Full coverage under great conditions	Full protection while you keep costs under control	Protect against all unexpected repair risks including all secondary costs	For customers who can't afford to down tools
Regular maintenance	✓	✓	✓	✓	✓	✓
Repair costs		✓	✓	✓	✓	✓
Excess		€490	€190	€0	€0	€0
Travel costs, recovery/towing, troubleshooting with added diagnostics tools, performance testing, oils and filters, if engine/gearbox is repaired					✓	✓
After hours and weekend surcharge						✓
Replacement machine						✓

<sup>1</sup> Valid for UK, Germany and France. Platinum only available at participating dealers.



8 years / 8,000 operating hours

With our new Fendt Care rates, Fendt offers extensive coverage for the reliability and repair risk of new machines. Fendt Care gives you complete cost control with exceptional service. From a service agreement to the full carefree package including replacement machine, Fendt has a flexible and tailored solution for your fleet.

# Quick and simple servicing.



Maintenance activities, such as checking the oil level or changing the filter, are performed quickly and easily on the Fendt 1000 Vario. The engine compartment is especially easy to access thanks to the removable side panels.



The cab filter is easily accessible in the entrance area and can be easily cleaned when needed.



The cab is cleaned quickly: The driver seats (super comfort seat Evolution) have a practical connection for a compressed air hose, which can be used to clean the cab.

# Fendt extras.



Fendt extras are a great addition to your Fendt machine. Choose from an extensive range of products including lubricants, AdBlue, care kits, cab accessories and much more. All extras are available for purchase exclusively from your Fendt dealer.



# What can we do for you?

### What makes Fendt Services different?

For us, service means knowing and understanding your work in order to meet your demands for reliability and safety and to act in your economic interest. We stand behind our products and have developed them for the highest demands and long-term operation. Our service is the partnership aspect for your work.

### How do I get a software update?

Fendt software is update-compatible, so your Fendt always features the latest technology. This ensures that your Fendt machine is technologically advanced, that it maintains its value, and keeps your investment as up to date in the future as it was on the first day you bought it. Contact your Fendt dealer for details.

### What is Fendt Expert?

Become an expert on the Vario Profi with Fendt Expert driver training: Are you already familiar with all the functions that the technology has to offer? Take advantage of the technology in every Fendt Vario and learn how to make best use of every feature, with Fendt Expert. Our team of professional trainers will advise you on how to use the full potential of your Fendt tractor. Contact your dealer for details and register today.

### fendt.com

Find everything online – from brochures to technical specifications, from reports about customers or our company to our Fendt event calendar.

### Fendt Configurator

With the Fendt Vehicle Configurator, you can choose from all the available equipment variations and put together the optimally equipped vehicle for your farm. The Fendt Configurator is available online at [www.fendt.com](http://www.fendt.com), where you will find a quick link to it directly on the start page.

### fendt.tv

Fendt around the clock – our Fendt Media Library makes it possible. Our Internet TV provides you with news and information about Fendt 24/7.

### Test drives

Go to [fendt.com](http://fendt.com) and select "Fendt Services" on the "Service" page, select the "Demo Service", then register for a test drive with the tractor of your choice.





# FENDT

It's Fendt. Because we understand Agriculture.



[www.fendt.com](http://www.fendt.com)

AGCO GmbH – Fendt Marketing  
87616 Marktberdorf, Germany

 **AGCO**  
Your Agriculture Company

Fendt is a worldwide brand of AGCO.  
All details regarding scope of delivery, appearance, performance, dimensions and weights, fuel consumption and running costs of vehicles reflect the latest information available at the time of print. These may change by the time of purchase. Your Fendt dealer will be happy to inform you about any changes. The vehicles shown do not feature country-specific equipment.